

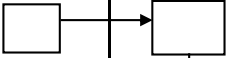





Prosedur Layanan Pembayaran Gaji (1)

No	Kegiatan	Pelaksana				Mutu Baku		Keterangan	
		Juru Bayar	PUMK Belanja Pegawai	Kasubag Dana Rutin	Bendahara Pengeluaran	Kelengkapan	Waktu	Output	
1	menghimpun SK Mutasi dan Nota BKN dan membuat daftar gaji					SK Mutasi dan Nota BKN tentang Kenaikan Pangkat (KP), Kenaikan Tunjangan Fungsional (KTF) dan Tunjangan Struktural (TS)	1 hari	Daftar gaji bulanan, kekurangan gaji, gaji terusan, gaji susulan dan uang duka.	
2	membuat SPP-LS					SPS-LS, Daftar Gaji Bulanan	1 Hari	Daftar Gaji, SPP-LS	
3	memeriksa daftar gaji					SPPS-LS, Daftar Gaji Bulanan	1 hari	SPM, SPP-LS, Daftar Rekapitulasi Gaji	

Prosedur Layanan Pembayaran Gaji (2)

No	Kegiatan	Pelaksana				Mutu Baku		Keterangan	
		Petugas Verifikasi	Kabag Keuangan	Ka. BAUK	PR II	Kelengkapan	Waktu	Output	
4	Cek dan paraf SPM					SPM	1 hari	SPM	
5	Cek dan tanda tangan SPM					SPP-LS, rekapitulasi gaji, SPM	1 Hari	SPM	